

Technical Data Sheet

Structure-Borne Sound Probe T10



The Structure-Borne Sound Probe T10 is used for condition monitoring of machines, plants and processes where detectable structure-borne sound in the ultrasonic range is generated. Changes in the sound signals indicate a change in the condition and/or process of the test object. The detection of these changes forms the basis for condition monitoring in preventive maintenance.

The Structure-Borne Sound Probe T10 is used when the installation space is very limited or the test object must not be loaded with a large sensor mass. The Structure-Borne Sound Probe T10 is also suitable for use on non-magnetic surfaces.

The type of coupling depends on the type of test. The probe can be coupled by hand for short-term measurements or fixed with beeswax for recurring measurements with recording of measurement data. For permanent monitoring or fixed mounting within a safety cover/zone, the probe is glued on.

General data

Order number	100 01 0378
Dimensions (L × W × H)	□ 11 × 9 mm (housing without connector)
Weight	5 g
Electrical connection	UNF 10-32 (Microdot)

Acoustic data

Center frequency	25,0 ± 3,0 kHz
Sensitivity	6,0 mV / 1 m/s ² @ center frequency

① The specified acoustic data apply from a frequency of 5 kHz.

Materials

Housing	Stainless steel
Probe delay	PEEK

Ambient conditions

Operating/storage temperature	-40 ... +110 °C
Protection type	IP64

Order details

Scope of delivery	<ul style="list-style-type: none">• Structure-Borne Sound Probe T10• Sensor cable UNF 12-32 – BNC, 1,5 m• Transportation case• Calibration certificate• Technical data sheet
-------------------	--

Frequency response

Frequency response at excitation 20 m/s²

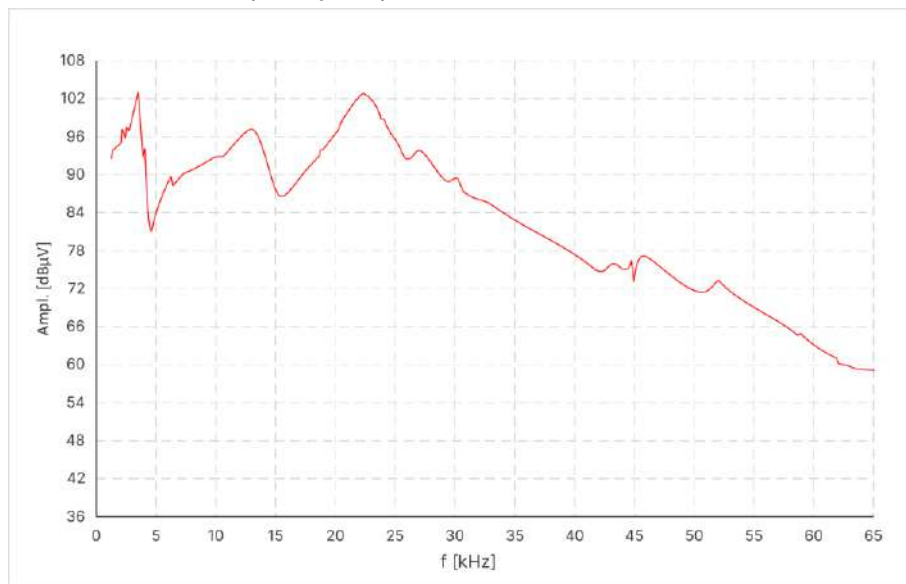

Coupling			
Inspection method	Short-term measurement	Recurring measurement with recording of measurement data	Permanent monitoring/ fixed mounting
Couplant / coupling accessories (recommended)	Grease (Vaseline), Coupling oil or gel for ultrasonic testing	Beeswax	Cyanoacrylate adhesive (e.g. Loctite 401) or grease (Vaseline), coupling oil or gel in combination with clamping mechanism
Coupling method	1: Pressing on by hand	2: Fixing with beeswax (short-term coupling)	3: Gluing/ installing (long-term coupling)

ATTENTION

The coupling method has a significant influence on the measurement results!

Frequency response depending on the coupling method

Frequency response at excitation 20 m/s²

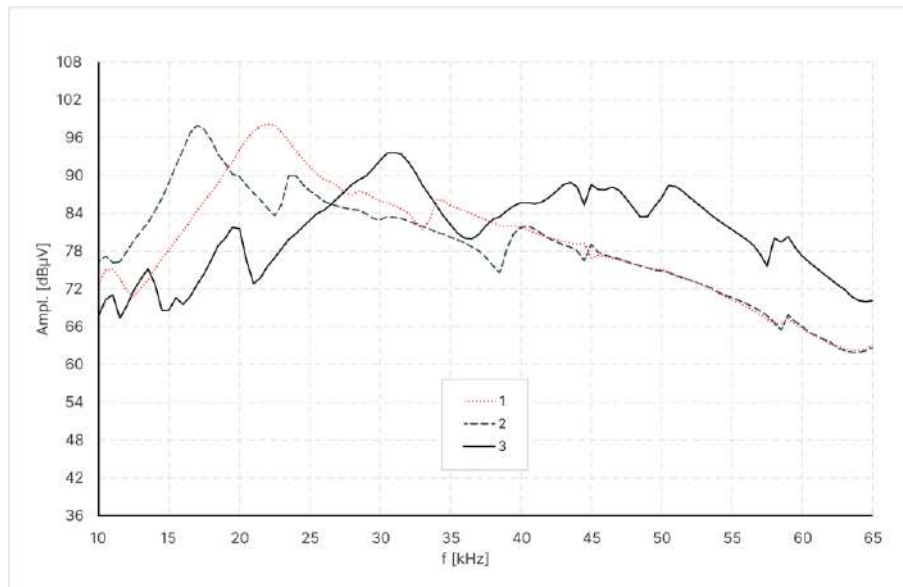

Technical drawing

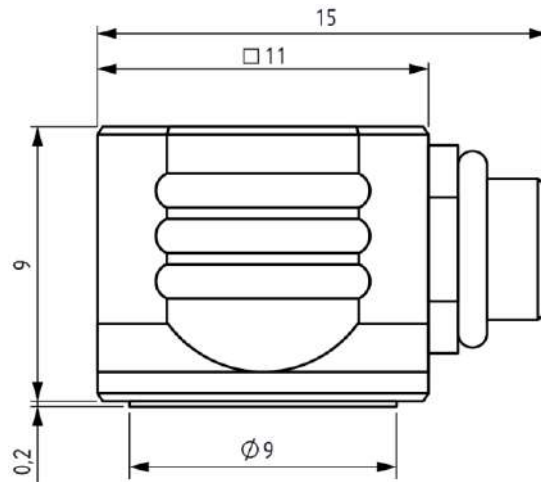

Drawings are not to scale. Dimensions in mm, unless otherwise specified. Information is subject to change without notice.

Manufacturer

SONOTEC GmbH
Nauendorfer Str. 2
06112 Halle (Saale)
Germany
Phone: +49 345 13317-0
mySONAPHONE@sonotec.de
www.sonotec.eu

Contact USA

SONOTEC US Inc.
190 Blydenburgh Rd
Suite 8, 2nd Floor
Islandia, New York 11749, USA
Phone: +1 631 4154758
sales@sonotecusa.com
www.sonotecusa.com