

Oil/water cooler TAK/TP

Cooling systems

Cooling of lubricating oil, heat recovery



The cooler ranges TAK/TP were originally designed for hydraulic systems, but they are equally suitable for cooling lubricating oils, heat recovery, etc.

The tube bundle is designed in that it may expand to both sides, consequently minimizing thermal stresses. The unique tube-to-tube plate joint ensures high reliability.



Materials used:

These coolers are available in both industrial and marine versions. (Tube bundles made of stainless steel on request)

Industrial version (standard)	
Tubes	Brass (EN CW614N)
Tube retainer	Brass
Housing	Aluminium
Headers	Brass (EN CW614N)
Gaskets	Nitrile

Marine version	
Tubes	90/10 copper/nickel

Oil/water cooler TAK/TP

Cooling systems

Cooling capacities, diagramme of performance, diagramme of pressure loss

Tubular heat cooler							
Coolers	Cooling capacity [kW]	Volume flow of oil [l/min]	Volume flow of water [l/min]	Pressure loss of oil [bar]	Pressure loss of water [bar]	Surface [m ²]	Maximum volume flow of water/sea water [l/min]
TAK/TP-A1	3	30	15	0.1	0.02	0.13	
TAK/TP-A2	6	46	23	0.19	0.05	0.22	
TAK/TP-A3	9	56	28	0.36	0.09	0.32	50/35
TAK/TP-A4	13	64	32	0.6	0.13	0.46	
TAK/TP-A5	16	56	28	0.56	0.12	0.68	
TAK/TP-B1	8	66	33	0.16	0.02	0.33	
TAK/TP-B2	12	80	40	0.32	0.03	0.48	
TAK/TP-B3	18	104	52	0.96	0.07	0.66	80/50
TAK/TP-B4	25	106	53	1	0.11	0.9	
TAK/TP-B5	29	98	49	1.04	0.14	1.16	
TAK/TP-C1	16	100	50	0.28	0.04	0.64	
TAK/TP-C2	26	120	60	0.55	0.07	0.9	
TAK/TP-C3	36	140	70	0.74	0.13	1.23	140/90
TAK/TP-C4	48	160	80	1.06	0.17	1.6	
TAK/TP-C5	56	140	70	0.95	0.16	2.07	
TAK/TP-C6	70	160	80	0.84	0.26	3.02	
TAK/TP-D1	40	180	90	0.4	0.07	1.58	
TAK/TP-D2	52	200	100	0.55	0.09	2.14	
TAK/TP-D3	66	220	110	0.62	0.12	2.79	190/110
TAK/TP-D4	84	240	120	0.8	0.16	3.57	
TAK/TP-D5	108	260	130	1	0.19	4.48	
TAK/TP-D6	120	240	120	0.96	0.21	5.38	
TAK/TP-E1	76	320	160	0.44	0.09	3.27	
TAK/TP-E2	106	360	180	0.64	0.13	4.24	
TAK/TP-E3	134	400	200	0.9	0.2	5.45	340/215
TAK/TP-E4	175	420	210	1.1	0.25	6.82	
TAK/TP-E5	205	400	200	1.15	0.28	8.22	
TAK/TP-E6	240	360	180	1.1	0.28	10.27	
TAK/TP-F1	133	720	360	0.36	0.09	7.2	
TAK/TP-F2	180	780	390	0.5	0.13	9.14	
TAK/TP-F3	250	840	420	0.62	0.17	11.81	800/500
TAK/TP-F4	325	900	450	0.76	0.25	14.6	
TAK/TP-F5	410	960	480	1	0.32	17.3	
TAK/TP-F6	500	900	450	1.16	0.52	21.54	

The table shows the performance assigned to the cooler with usual process data:

Oil outlet temperature: 50 °C; water inlet temperature: 25 °C, oil viscosity: 38 Cst and 50 °C. Any change of the parameters selected may result in a different selection of oil cooler.

Oil/water cooler TAK/TP

Cooling systems

Series A-C

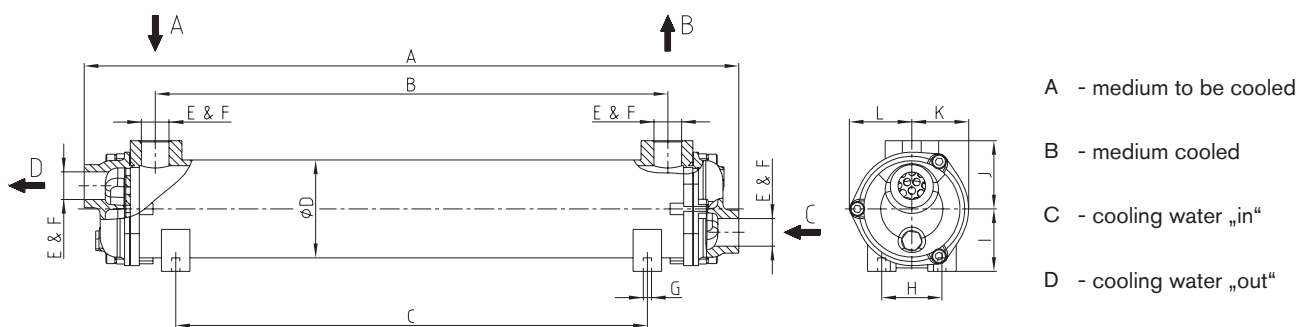

TAK/TP Series A-C												
Coolers	A	B	C	D	E & F	G	H	I	J	K	L	Weight
TAK/TP-A1	195	72	38									3
TAK/TP-A2	263	138	103									3.5
TAK/TP-A3	349	225	189									4
TAK/TP-A4	448	326	288	Ø86	G 3/4"	4xM8	53	55	60	50	55	4.7
TAK/TP-A5	576	450	415									5.5
TAK/TP-A6	731	603	557									10
TAK/TP-B1	273	123	109									5
TAK/TP-B2	355	205	191									6
TAK/TP-B3	452	302	289	Ø108	G 1"	4xM8	77	65	70	60	55	7
TAK/TP-B4	587	437	425									8.2
TAK/TP-B5	730	580	566									10
TAK/TP-C1	372	182	93									9
TAK/TP-C2	472	287	193									10
TAK/TP-C3	600	415	320	Ø130	G 1 1/4"	4xM10	78	75	80	70	80	12.5
TAK/TP-C4	744	557	465									14.5
TAK/TP-C5	922	737	643									17.5
TAK/TP-C6	1332	1146	1055									30

Max. perm. oil temperature 120 °C. Max. oil pressure 14 bars. Max. water pressure 10 bars.

Ordering example:

TAK/TP	A	1	M
Type	Series	Size	Seawater version ¹⁾

¹⁾ Code letter can be omitted with industrial design.

Oil/water cooler TAK/TP

Cooling systems

Series D-F

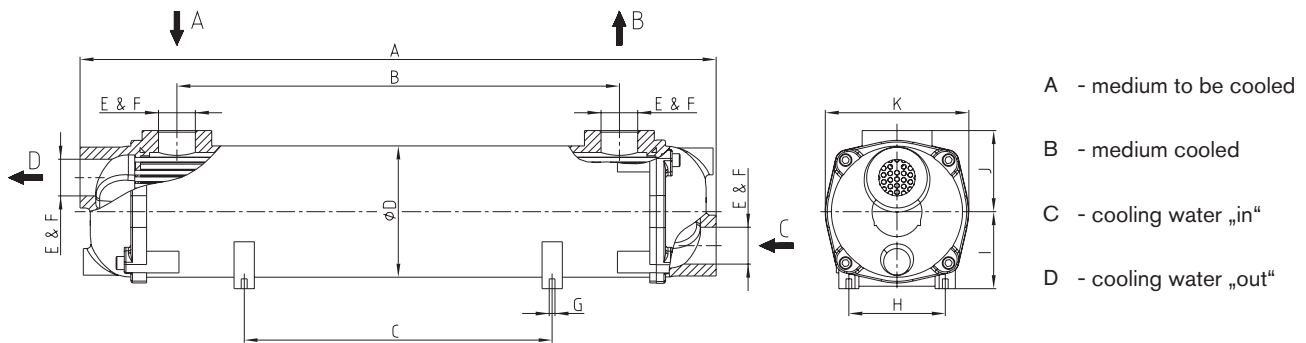

TAK/TP Series D-F												
Coolers	A	B	C	D	E & F	G	H	I	J	K	L	Weight
TAK/TP-D1	505	270	109									20
TAK/TP-D2	634	402	238									24
TAK/TP-D3	780	546	384									27
TAK/TP-D4	954	722	558	Ø162	G 1 1/2"	4xM10	119	95	100	177	-	32
TAK/TP-D5	1,160	928	764									38
TAK/TP-D6	1,364	1,132	968									45
TAK/TP-E1	675	372	239									33
TAK/TP-E2	816	513	380									39
TAK/TP-E3	998	696	560									45
TAK/TP-E4	1,204	901	766	Ø198	G 2"	4xM12	120	110	120	206	-	54
TAK/TP-E5	1,408	1,102	968									64
TAK/TP-E6	1,712	1,406	1,272									74
TAK/TP-F1	754	330	236									47
TAK/TP-F2	900	476	382									57
TAK/TP-F3	1,077	654	560									68
TAK/TP-F4	1,280	856	762	Ø278	G 3"	4xM16	180	155	170	288	-	79
TAK/TP-F5	1,484	1,060	966									91
TAK/TP-F6	1,790	1,364	1,270									105

Max. perm. oil temperature 120 °C. Max. oil pressure 14 bars. Max. water pressure 10 bars.

Ordering example:

TAK/TP	D	1	M
Type	Series	Size	Seawater version ¹⁾

¹⁾ Code letter can be omitted with industrial design.

Oil/water cooler TAK/TP

Cooling systems

Performance diagrammes

Performance diagramme of A series

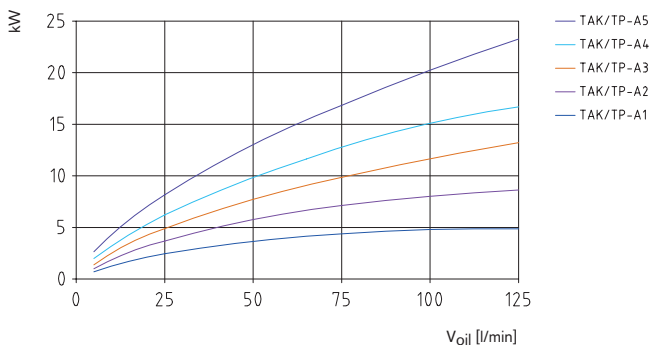

Performance diagramme of B series

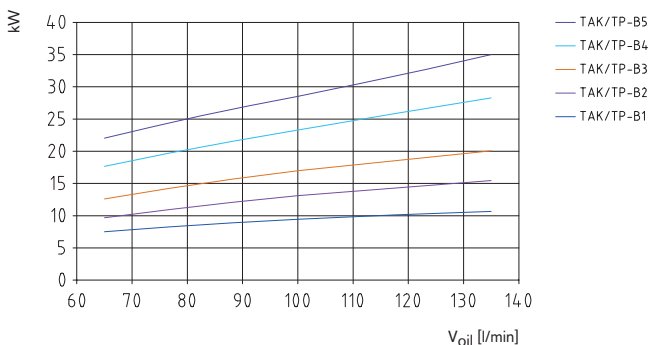

Performance diagramme of C series

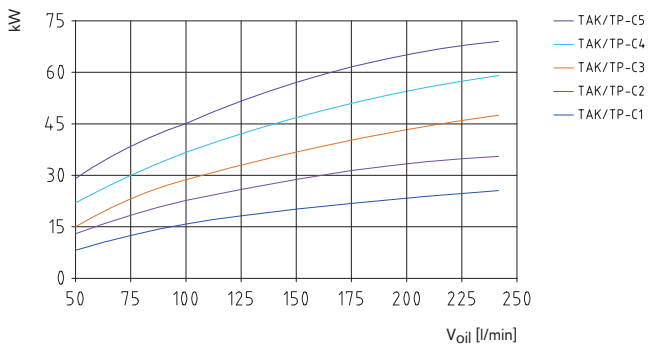

Performance diagramme of D series

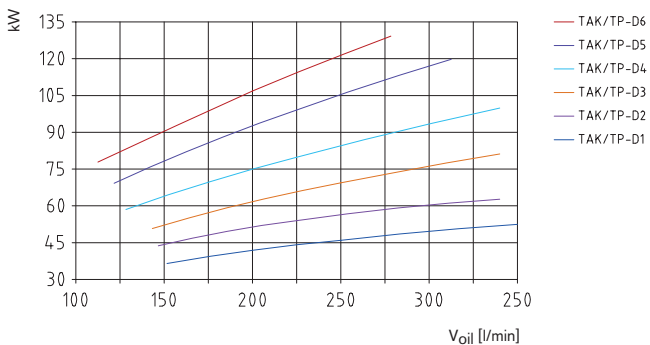

Performance diagramme of E series

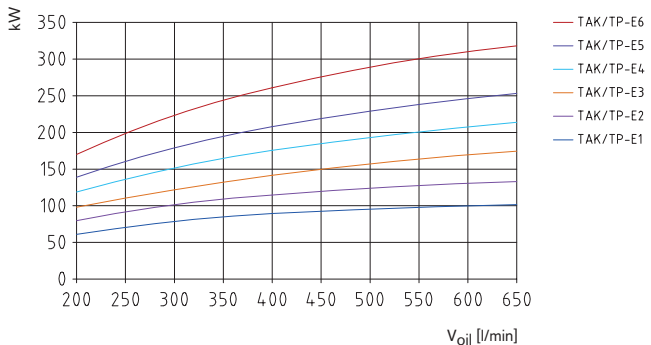

Performance diagramme of F series

